

L:
 CBL-RTPD3SABMBS-1m 1000mm±10mm
 CBL-RTPD3SABMBS-2m 2000mm±20mm
 CBL-RTPD3SABMBS-3m 3000mm±20mm
 CBL-RTPD3SABMBS-4m 4000mm±30mm
 CBL-RTPD3SABMBS-5m 5000mm±30mm

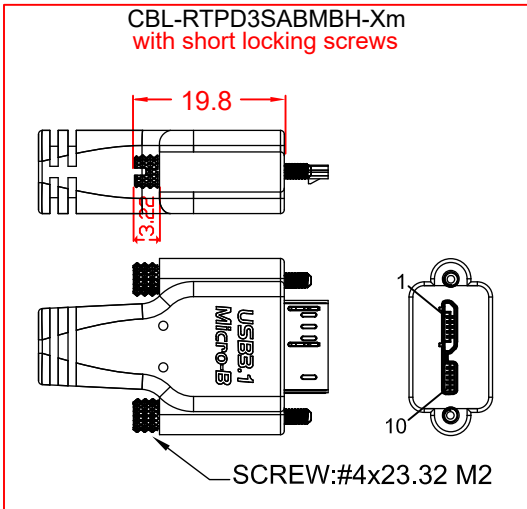

No	MATERIALS LIST:
1.	CABLE: 3 x (2 x 26 AWG)ST + 2 x 24 AWG O.D.:8.0mm COLOR:BLACK
2.	CONNECTOR:USB 3.0 A/M, 9P, BLUE INSULATOR SOLDER TYPE, NICKEL PLATED SHELL
3.	CONNECTOR:USB 3.0 MicroB/M, 10P, BLACK INSULATOR SOLDER TYPE, NICKEL PLATED SHELL
4.	PVC MOLDED HOUSING, BLACK COLOR
5.	SCREW:#4x33 M2

Jargy part no.	Client part no.	Approved	SCALE	UNIT
CBL-RTPD3SABMBS-xm				mm
Drawing Name		Drawn	Date	REV.
USB 3.0 A to MicroB Cable M/M				1.0

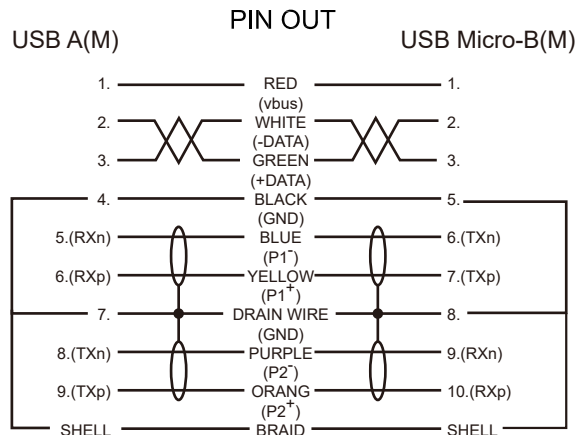
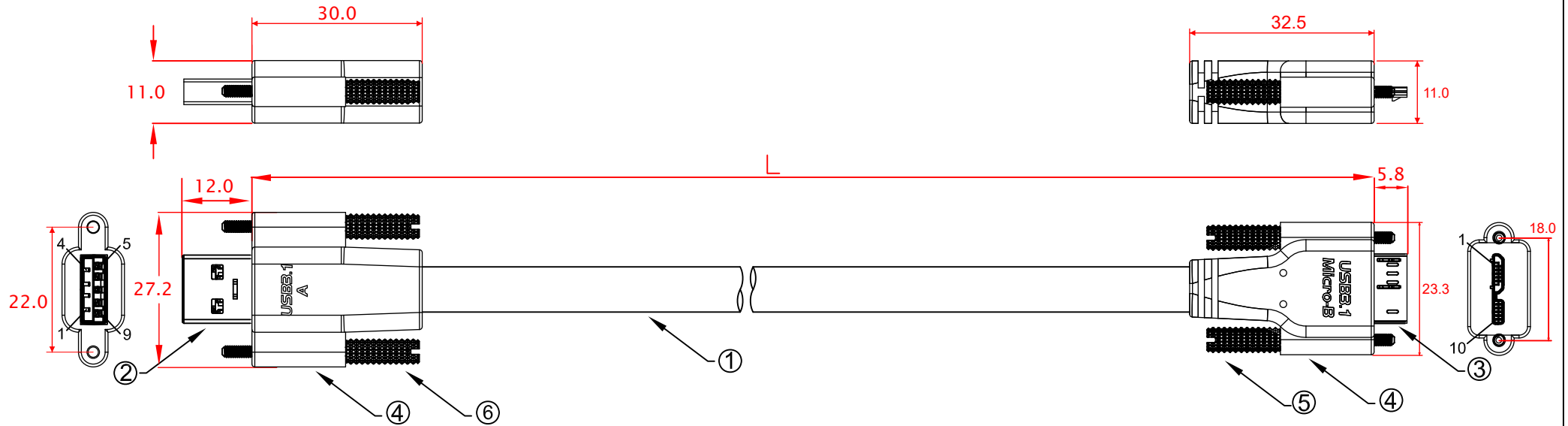

- L:
- CBL-RTPD3SABMBSS-1m 1000mm±10mm
 - CBL-RTPD3SABMBSS-2m 2000mm±20mm
 - CBL-RTPD3SABMBSS-3m 3000mm±20mm
 - CBL-RTPD3SABMBSS-4m 4000mm±30mm
 - CBL-RTPD3SABMBSS-5m 5000mm±30mm

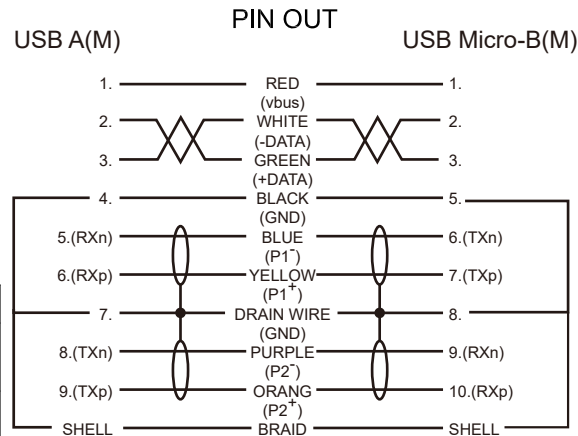

CBL-RTPD3SABMBSH-Xm with short locking screws

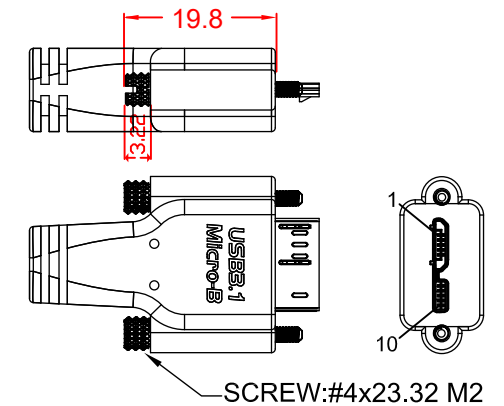

No	MATERIALS LIST:
1.	CABLE: 3 x (2 x 26 AWG)ST + 2 x 24 AWG O.D.:8.0mm COLOR:BLACK
2.	CONNECTOR:USB 3.0 A/M, 9P, BLUE INSULATOR SOLDER TYPE, NICKEL PLATED SHELL
3.	CONNECTOR:USB 3.0 MicroB/M, 10P, BLACK INSULATOR SOLDER TYPE, NICKEL PLATED SHELL
4.	PVC MOLDED HOUSING, BLACK COLOR
5.	SCREW:#4x33 M2
6.	SCREW:#4x34.5 M2

Jargy part no.	Client part no.	Approved	SCALE	UNIT
CBL-RTPD3SABMBSS-xm				mm
Drawing Name		Drawn	Date	REV.
USB 3.0 A to MicroB Cable M/M				1.0

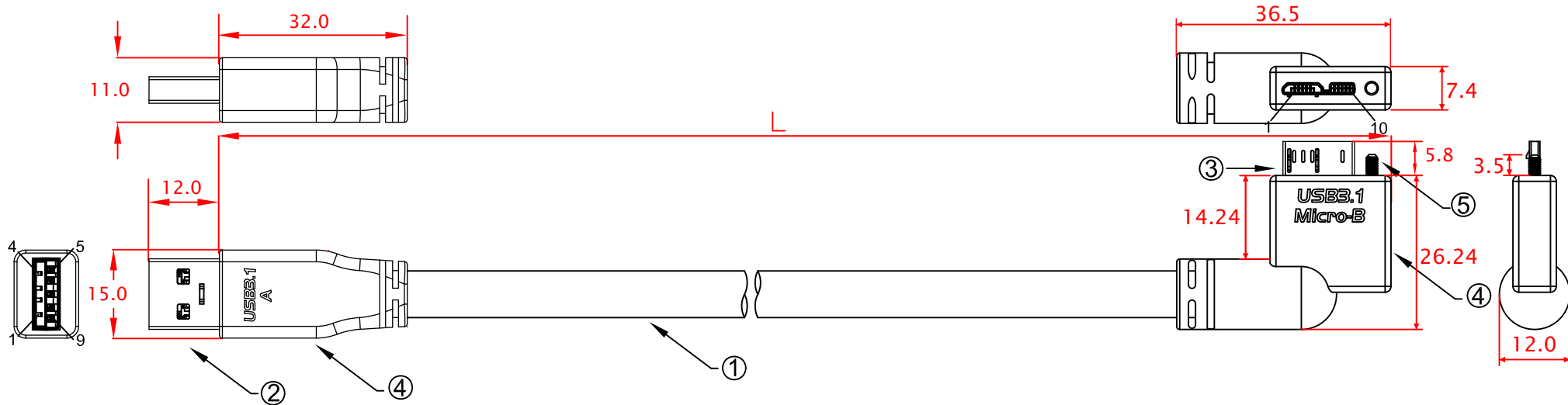

L:
 CBL-RTPD3SABMBHM-1mLA 1000mm±10mm
 CBL-RTPD3SABMBHM-2mLA 2000mm±20mm
 CBL-RTPD3SABMBHM-3mLA 3000mm±20mm
 CBL-RTPD3SABMBHM-4mLA 4000mm±30mm
 CBL-RTPD3SABMBHM-5mLA 5000mm±30mm

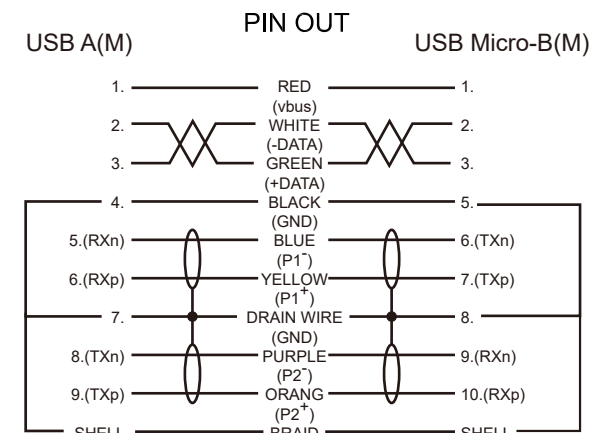

No	MATERIALS LIST:
1.	CABLE: 3 x (2 x 26 AWG)ST + 2 x 24 AWG O.D.:8.0mm COLOR:BLACK
2.	CONNECTOR:USB 3.0 A/M, 9P, BLUE INSULATOR SOLDER TYPE, NICKEL PLATED SHELL
3.	CONNECTOR:USB 3.0 MicroB/M, 10P, BLACK INSULATOR SOLDER TYPE, NICKEL PLATED SHELL
4.	PVC MOLDED HOUSING, BLACK COLOR
5.	SCREW:#4x23.32 M2

Jargy part no.	Client part no.	Approved	SCALE	UNIT
CBL-RTPD3SABMBHM-xmLA				mm
Drawing Name		Drawn	Date	REV.
USB 3.0 A to MicroB Cable M/M				1.0

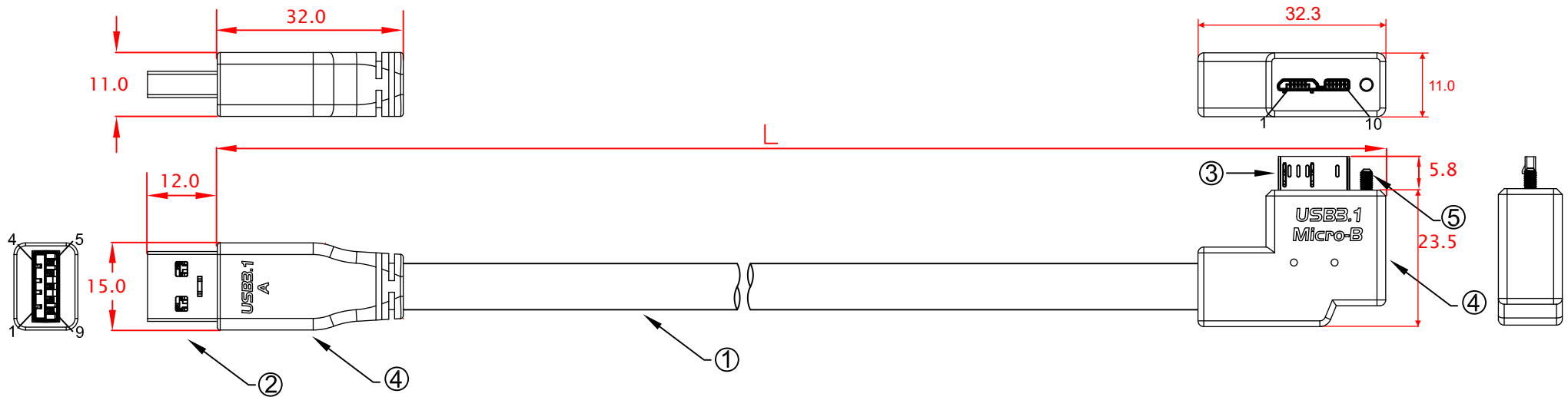

- L:
 CBL-RTPD3SABMBH-1mLA 1000mm±10mm
 CBL-RTPD3SABMBH-2mLA 2000mm±20mm
 CBL-RTPD3SABMBH-3mLA 3000mm±20mm
 CBL-RTPD3SABMBH-4mLA 4000mm±30mm
 CBL-RTPD3SABMBH-5mLA 5000mm±30mm

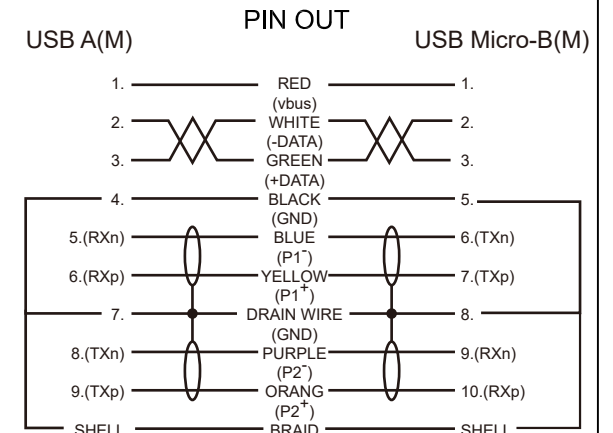

No	MATERIALS LIST:
1.	CABLE: 3 x (2 x 26 AWG)ST + 2 x 24 AWG O.D.:8.0mm COLOR:BLACK
2.	CONNECTOR:USB 3.0 A/M, 9P, BLUE INSULATOR SOLDER TYPE, NICKEL PLATED SHELL
3.	CONNECTOR:USB 3.0 MicroB/M, 10P, BLACK INSULATOR SOLDER TYPE, NICKEL PLATED SHELL
4.	PVC MOLDED HOUSING, BLACK COLOR
5.	SCREW:#4x23.32 M2

Jargy part no.	Client part no.	Approved	SCALE	UNIT
CBL-RTPD3SABMBH-xmLA				mm
Drawing Name		Drawn	Date	REV.
USB 3.0 A to MicroB Cable M/M				1.0

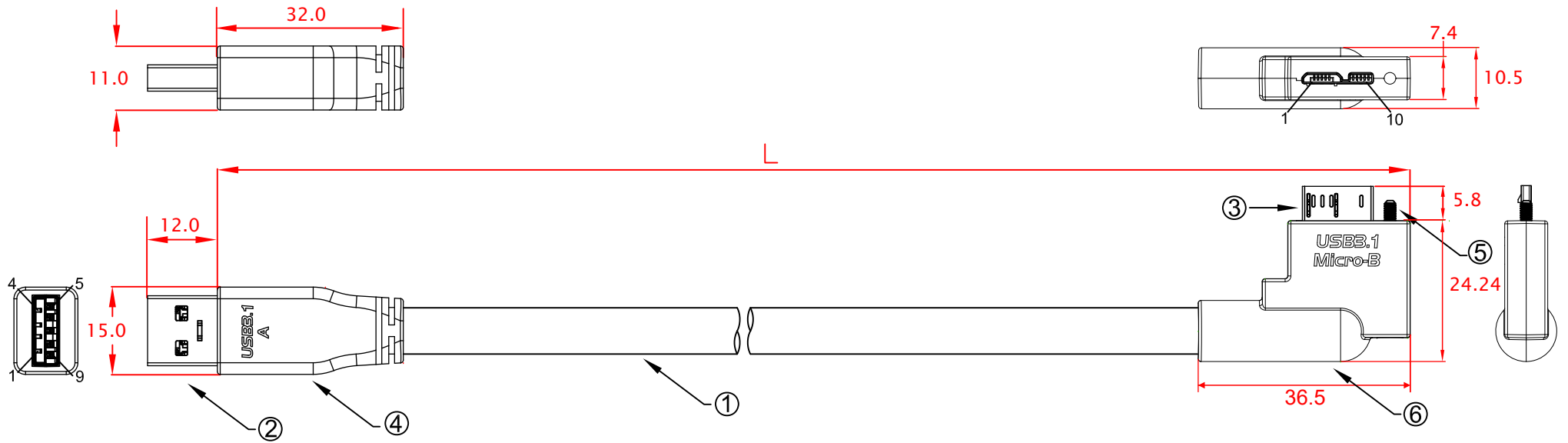

- L:
- CBL-RTPD3SABMBHN-1mLA 1000mm±10mm
 - CBL-RTPD3SABMBHN-2mLA 2000mm±20mm
 - CBL-RTPD3SABMBHN-3mLA 3000mm±20mm
 - CBL-RTPD3SABMBHN-4mLA 4000mm±30mm
 - CBL-RTPD3SABMBHN-5mLA 5000mm±30mm

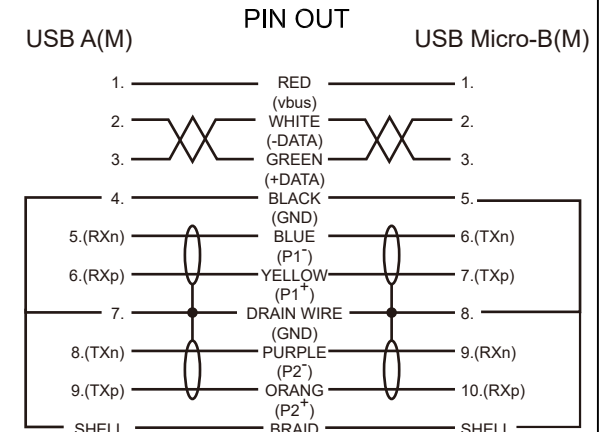

No	MATERIALS LIST:
1.	CABLE: 3 x (2 x 26 AWG)ST + 2 x 24 AWG O.D.:8.0mm COLOR:BLACK
2.	CONNECTOR:USB 3.0 A/M, 9P, BLUE INSULATOR SOLDER TYPE, NICKEL PLATED SHELL
3.	CONNECTOR:USB 3.0 MicroB/M, 10P, BLACK INSULATOR SOLDER TYPE, NICKEL PLATED SHELL
4.	PVC MOLDED HOUSING, BLACK COLOR
5.	SCREW:#4x23.32 M2
6.	ABS ASSEMBLY HOUSING, BLACK COLOR

Jargy part no.	Client part no.	Approved	SCALE	UNIT
CBL-RTPD3SABMBHN-xmLA				mm
Drawing Name		Drawn	Date	REV.
USB 3.0 A to MicroB Cable M/M				1.0

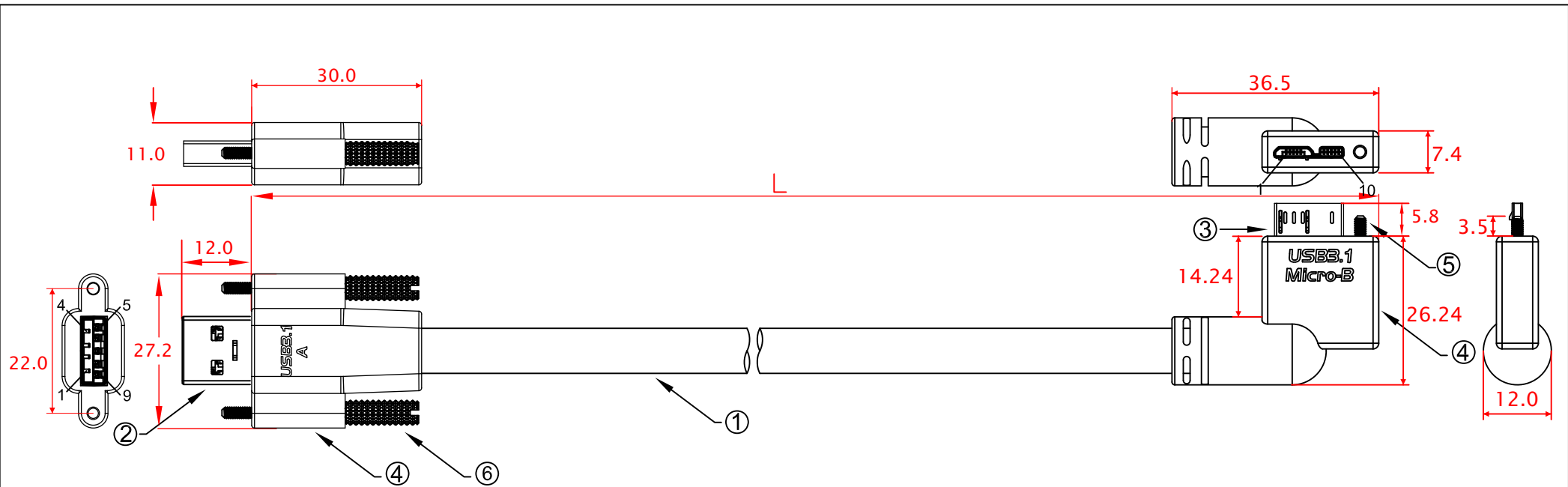

L:

CBL-RTPD3SABMBSHM-1mLA	1000mm±10mm
CBL-RTPD3SABMBSHM-2mLA	2000mm±20mm
CBL-RTPD3SABMBSHM-3mLA	3000mm±20mm
CBL-RTPD3SABMBSHM-4mLA	4000mm±30mm
CBL-RTPD3SABMBSHM-5mLA	5000mm±30mm

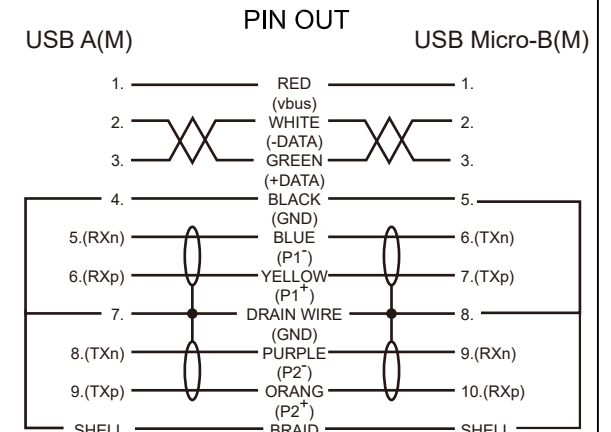

No	MATERIALS LIST:
1.	CABLE: 3 x (2 x 26 AWG)ST + 2 x 24 AWG O.D.:8.0mm COLOR:BLACK
2.	CONNECTOR:USB 3.0 A/M, 9P, BLUE INSULATOR SOLDER TYPE, NICKEL PLATED SHELL
3.	CONNECTOR:USB 3.0 MicroB/M, 10P, BLACK INSULATOR SOLDER TYPE, NICKEL PLATED SHELL
4.	PVC MOLDED HOUSING, BLACK COLOR
5.	SCREW:#4x23.32 M2
6.	SCREW:#4x34.5 M2

Jargy part no.	Client part no.	Approved	SCALE	UNIT
CBL-RTPD3SABMBSHM-xmLA				mm
Drawing Name		Drawn	Date	REV.
USB 3.0 A to MicroB Cable M/M				1.0

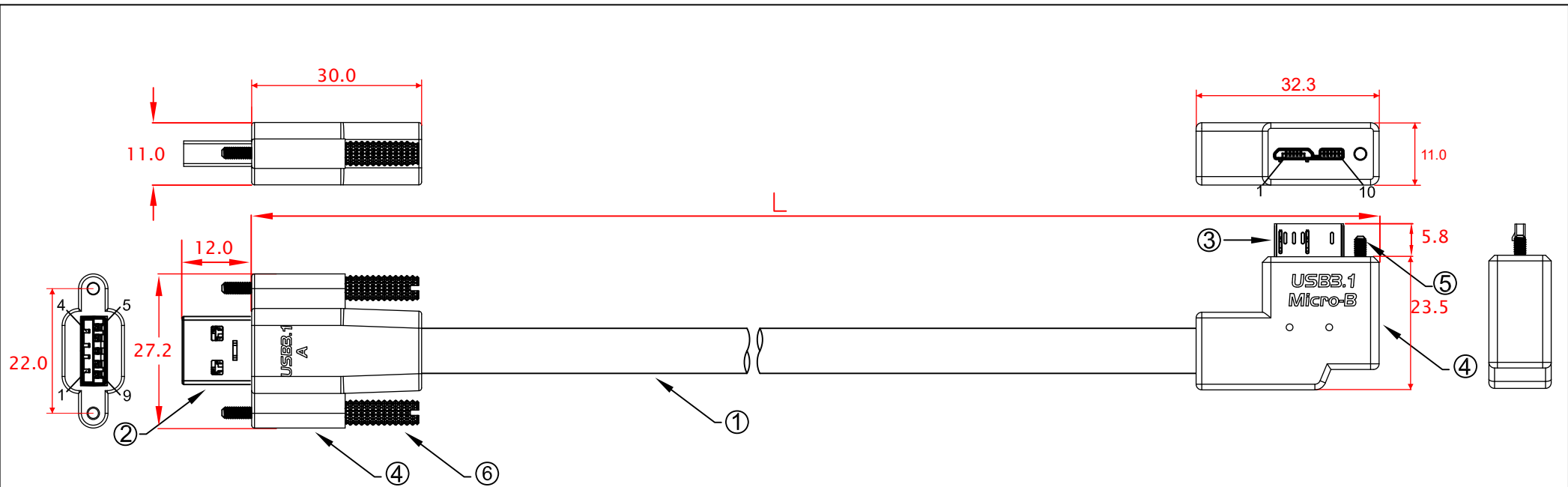

- L:
- CBL-RTPD3SABMBSH-1mLA 1000mm±10mm
 - CBL-RTPD3SABMBSH-2mLA 2000mm±20mm
 - CBL-RTPD3SABMBSH-3mLA 3000mm±20mm
 - CBL-RTPD3SABMBSH-4mLA 4000mm±30mm
 - CBL-RTPD3SABMBSH-5mLA 5000mm±30mm

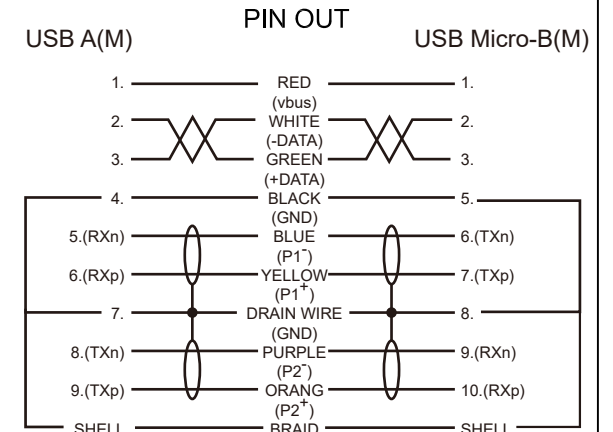

No	MATERIALS LIST:
1.	CABLE: 3 x (2 x 26 AWG)ST + 2 x 24 AWG O.D.:8.0mm COLOR:BLACK
2.	CONNECTOR:USB 3.0 A/M, 9P, BLUE INSULATOR SOLDER TYPE, NICKEL PLATED SHELL
3.	CONNECTOR:USB 3.0 MicroB/M, 10P, BLACK INSULATOR SOLDER TYPE, NICKEL PLATED SHELL
4.	PVC MOLDED HOUSING, BLACK COLOR
5.	SCREW:#4x23.32 M2
6.	SCREW:#4x34.5 M2

Jargy part no.	Client part no.	Approved	SCALE	UNIT
CBL-RTPD3SABMBSH-xmLA				mm
Drawing Name		Drawn	Date	REV.
USB 3.0 A to MicroB Cable M/M				1.0

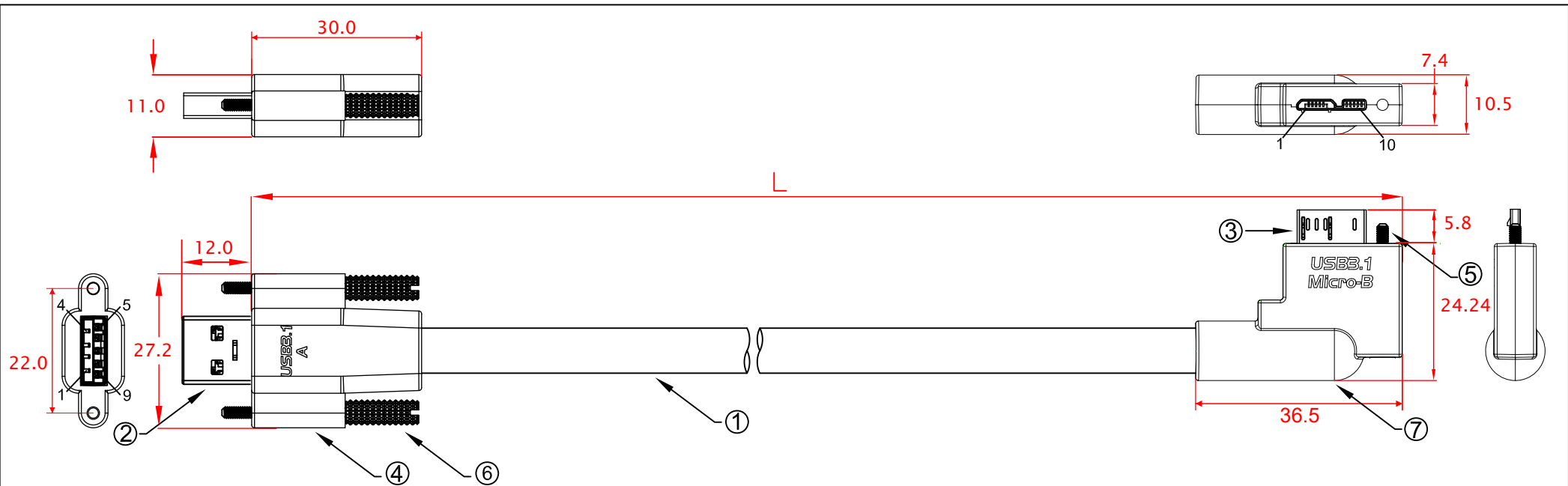

- L:
- CBL-RTPD3SABMBSHN-1mLA 1000mm±10mm
 - CBL-RTPD3SABMBSHN-2mLA 2000mm±20mm
 - CBL-RTPD3SABMBSHN-3mLA 3000mm±20mm
 - CBL-RTPD3SABMBSHN-4mLA 4000mm±30mm
 - CBL-RTPD3SABMBSHN-5mLA 5000mm±30mm

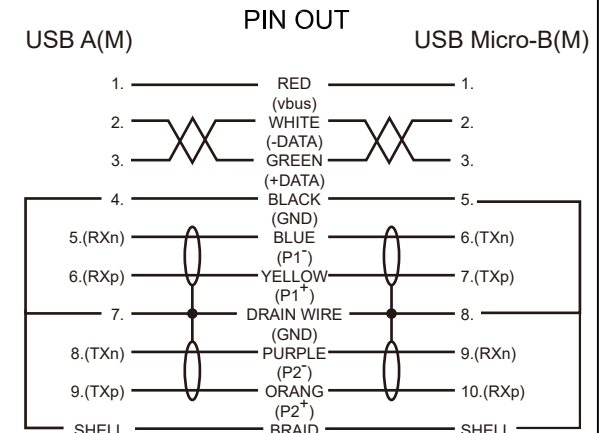

No	MATERIALS LIST:
1.	CABLE: 3 x (2 x 26 AWG)ST + 2 x 24 AWG O.D.:8.0mm COLOR:BLACK
2.	CONNECTOR:USB 3.0 A/M, 9P, BLUE INSULATOR SOLDER TYPE, NICKEL PLATED SHELL
3.	CONNECTOR:USB 3.0 MicroB/M, 10P, BLACK INSULATOR SOLDER TYPE, NICKEL PLATED SHELL
4.	PVC MOLDED HOUSING, BLACK COLOR
5.	SCREW:#4x23.32 M2
6.	SCREW:#4x34.5 M2
7.	ABS ASSEMBLY HOUSING, BLACK COLOR

Jargy part no.	Client part no.	Approved	SCALE	UNIT
CBL-RTPD3SABMBSHN-xmLA				mm
Drawing Name		Drawn	Date	REV.
USB 3.0 A to MicroB Cable M/M				1.0

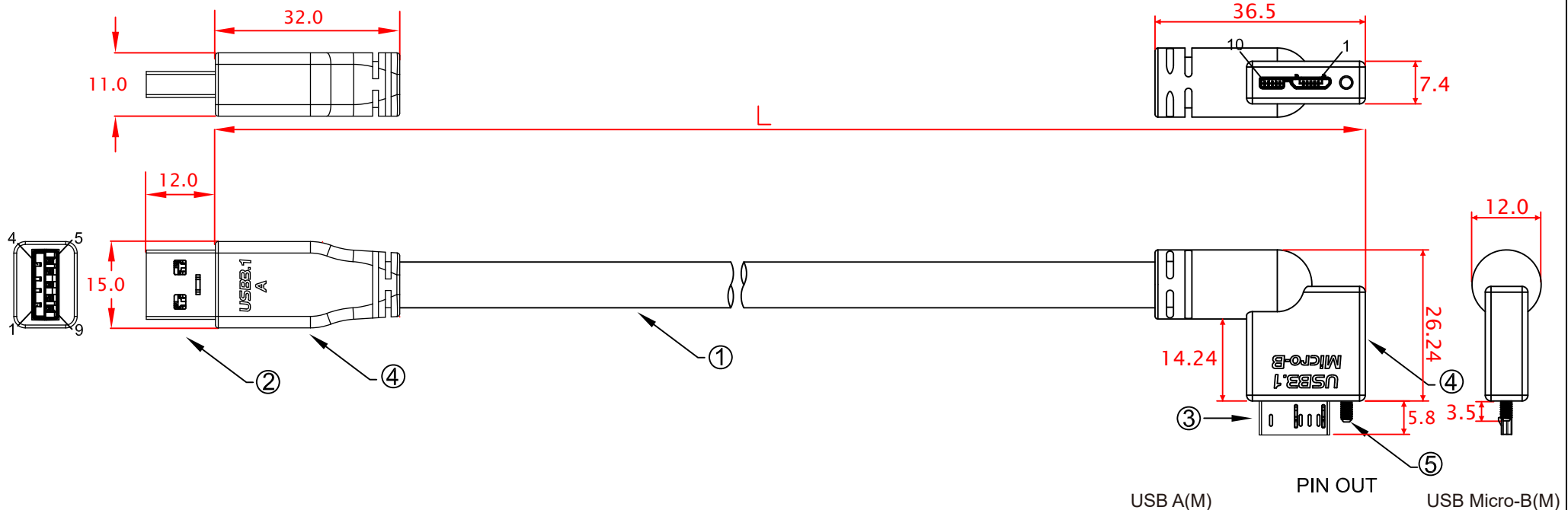

- L:
- | | |
|-----------------------|-------------|
| CBL-RTPD3SABMBHM-1mRA | 1000mm±10mm |
| CBL-RTPD3SABMBHM-2mRA | 2000mm±20mm |
| CBL-RTPD3SABMBHM-3mRA | 3000mm±20mm |
| CBL-RTPD3SABMBHM-4mRA | 4000mm±30mm |
| CBL-RTPD3SABMBHM-5mRA | 5000mm±30mm |

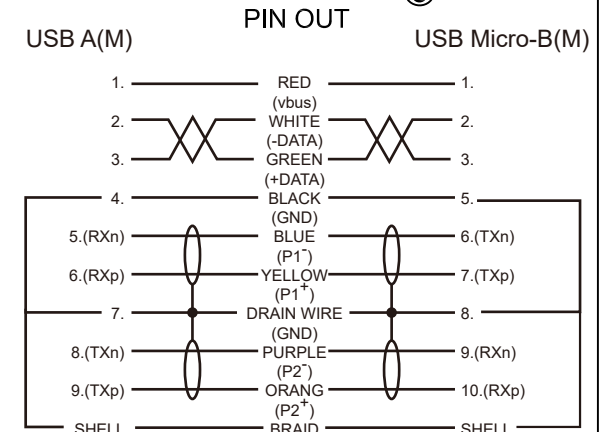

No	MATERIALS LIST:
1.	CABLE: 3 x (2 x 26 AWG)ST + 2 x 24 AWG O.D.:8.0mm COLOR:BLACK
2.	CONNECTOR:USB 3.0 A/M, 9P, BLUE INSULATOR SOLDER TYPE, NICKEL PLATED SHELL
3.	CONNECTOR:USB 3.0 MicroB/M, 10P, BLACK INSULATOR SOLDER TYPE, NICKEL PLATED SHELL
4.	PVC MOLDED HOUSING, BLACK COLOR
5.	SCREW:#4x23.32 M2

Jargy part no.	Client part no.	Approved	SCALE	UNIT
CBL-RTPD3SABMBHM-xmRA				mm
Drawing Name		Drawn	Date	REV.
USB 3.0 A to MicroB Cable M/M				1.0

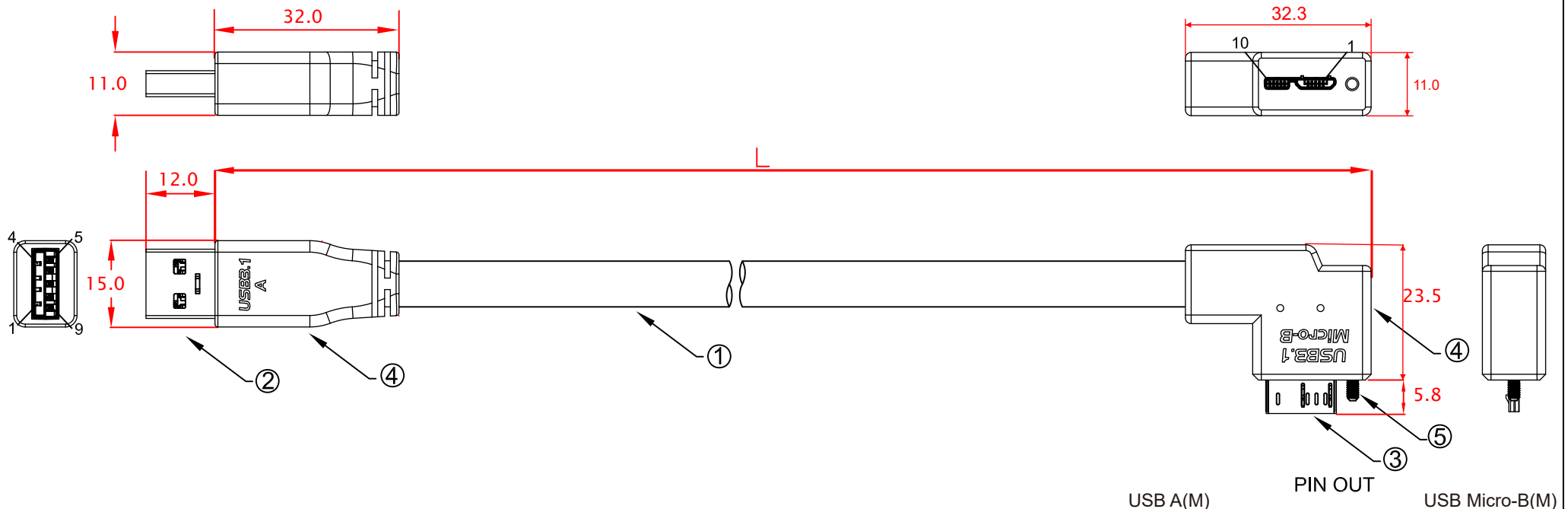

- L:
 CBL-RTPD3SABMBH-1mRA 1000mm±10mm
 CBL-RTPD3SABMBH-2mRA 2000mm±20mm
 CBL-RTPD3SABMBH-3mRA 3000mm±20mm
 CBL-RTPD3SABMBH-4mRA 4000mm±30mm
 CBL-RTPD3SABMBH-5mRA 5000mm±30mm

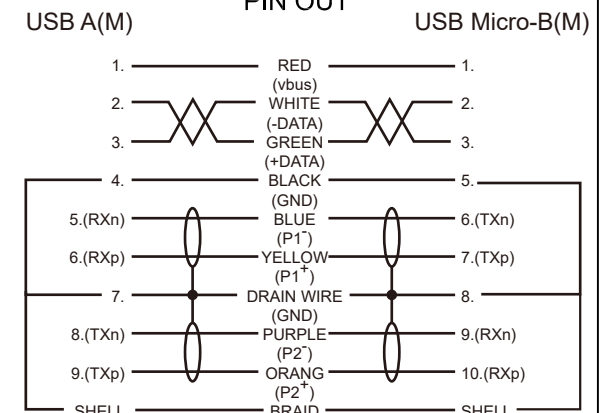

No	MATERIALS LIST:
1.	CABLE: 3 x (2 x 26 AWG)ST + 2 x 24 AWG O.D.:8.0mm COLOR:BLACK
2.	CONNECTOR:USB 3.0 A/M, 9P, BLUE INSULATOR SOLDER TYPE, NICKEL PLATED SHELL
3.	CONNECTOR:USB 3.0 MicroB/M, 10P, BLACK INSULATOR SOLDER TYPE, NICKEL PLATED SHELL
4.	PVC MOLDED HOUSING, BLACK COLOR
5.	SCREW:#4x23.32 M2

Jargy part no.	Client part no.	Approved	SCALE	UNIT
CBL-RTPD3SABMBH-xmRA				mm
Drawing Name		Drawn	Date	REV.
USB 3.0 A to MicroB Cable M/M				1.0

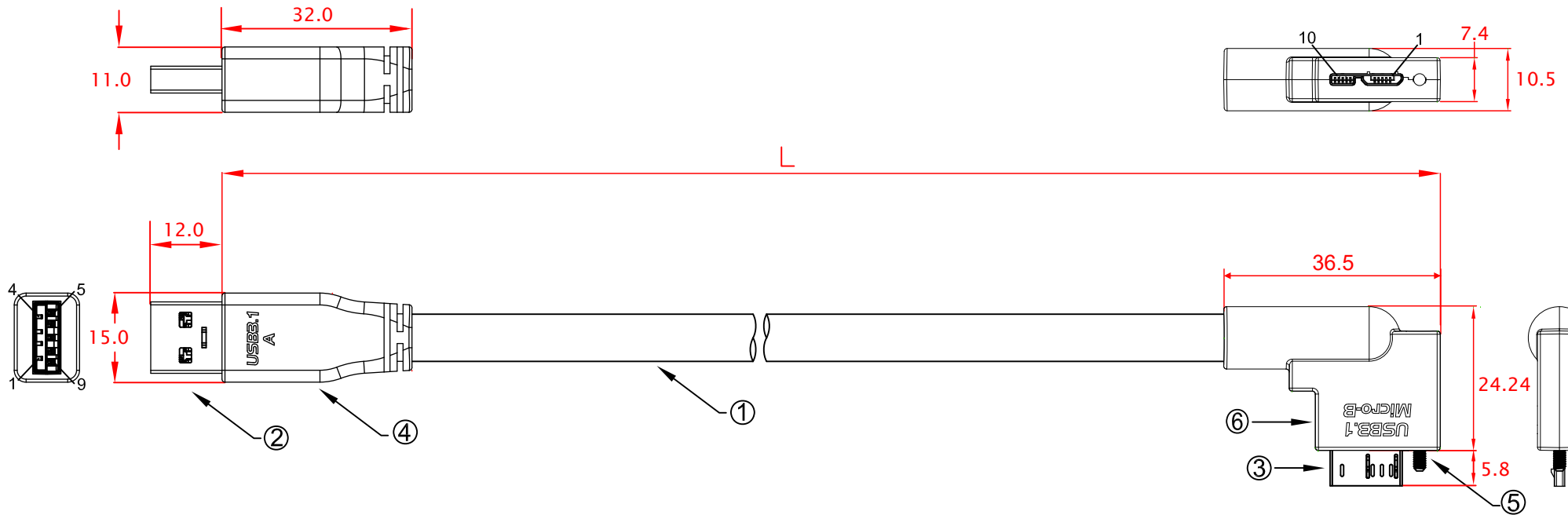

- L:
- CBL-RTPD3SABMBHN-1mRA 1000mm±10mm
 - CBL-RTPD3SABMBHN-2mRA 2000mm±20mm
 - CBL-RTPD3SABMBHN-3mRA 3000mm±20mm
 - CBL-RTPD3SABMBHN-4mRA 4000mm±30mm
 - CBL-RTPD3SABMBHN-5mRA 5000mm±30mm

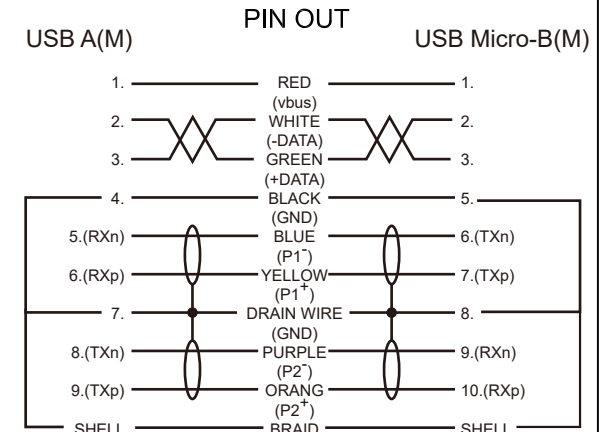

No	MATERIALS LIST:
1.	CABLE: 3 x (2 x 26 AWG)ST + 2 x 24 AWG O.D.:8.0mm COLOR:BLACK
2.	CONNECTOR:USB 3.0 A/M, 9P, BLUE INSULATOR SOLDER TYPE, NICKEL PLATED SHELL
3.	CONNECTOR:USB 3.0 MicroB/M, 10P, BLACK INSULATOR SOLDER TYPE, NICKEL PLATED SHELL
4.	PVC MOLDED HOUSING, BLACK COLOR
5.	SCREW:#4x23.32 M2
6.	ABS ASSEMBLY HOUSING, BLACK COLOR

Jargy part no.	Client part no.	Approved	SCALE	UNIT
CBL-RTPD3SABMBHN-xmRA				mm
Drawing Name		Drawn	Date	REV.
USB 3.0 A to MicroB Cable M/M				1.0

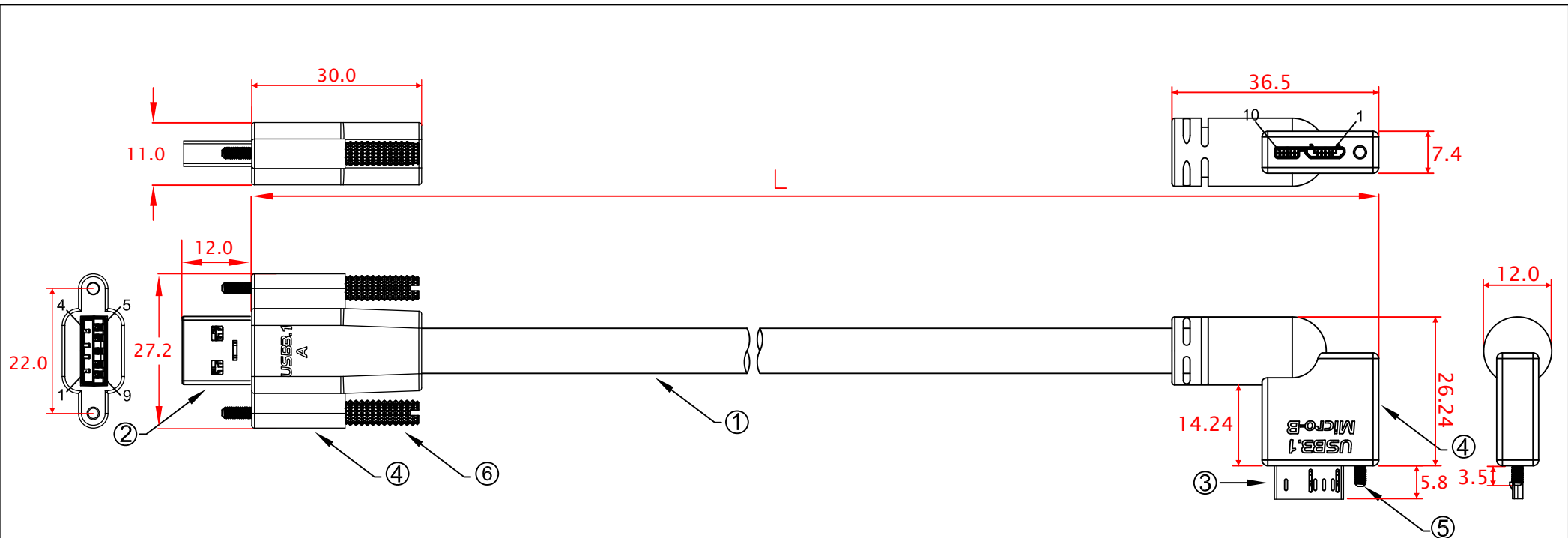

L:

CBL-RTPD3SABMBSHM-1mRA	1000mm±10mm
CBL-RTPD3SABMBSHM-2mRA	2000mm±20mm
CBL-RTPD3SABMBSHM-3mRA	3000mm±20mm
CBL-RTPD3SABMBSHM-4mRA	4000mm±30mm
CBL-RTPD3SABMBSHM-5mRA	5000mm±30mm

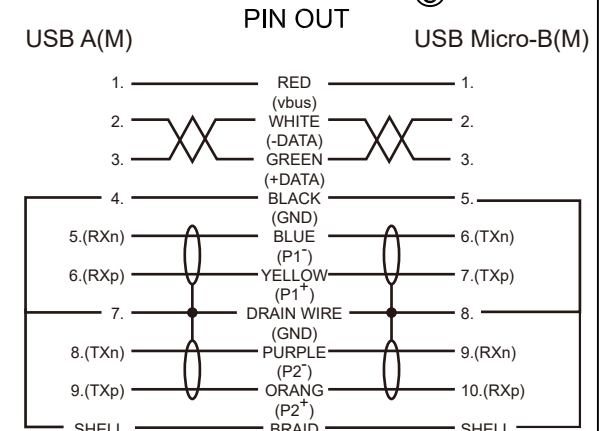

No	MATERIALS LIST:
1.	CABLE: 3 x (2 x 26 AWG)ST + 2 x 24 AWG O.D.:8.0mm COLOR:BLACK
2.	CONNECTOR:USB 3.0 A/M, 9P, BLUE INSULATOR SOLDER TYPE, NICKEL PLATED SHELL
3.	CONNECTOR:USB 3.0 MicroB/M, 10P, BLACK INSULATOR SOLDER TYPE, NICKEL PLATED SHELL
4.	PVC MOLDED HOUSING, BLACK COLOR
5.	SCREW:#4x23.32 M2
6.	SCREW:#4x34.5 M2

Jargy part no.	Client part no.	Approved	SCALE	UNIT
CBL-RTPD3SABMBSHM-xmRA				mm
Drawing Name		Drawn	Date	REV.
USB 3.0 A to MicroB Cable M/M				1.0

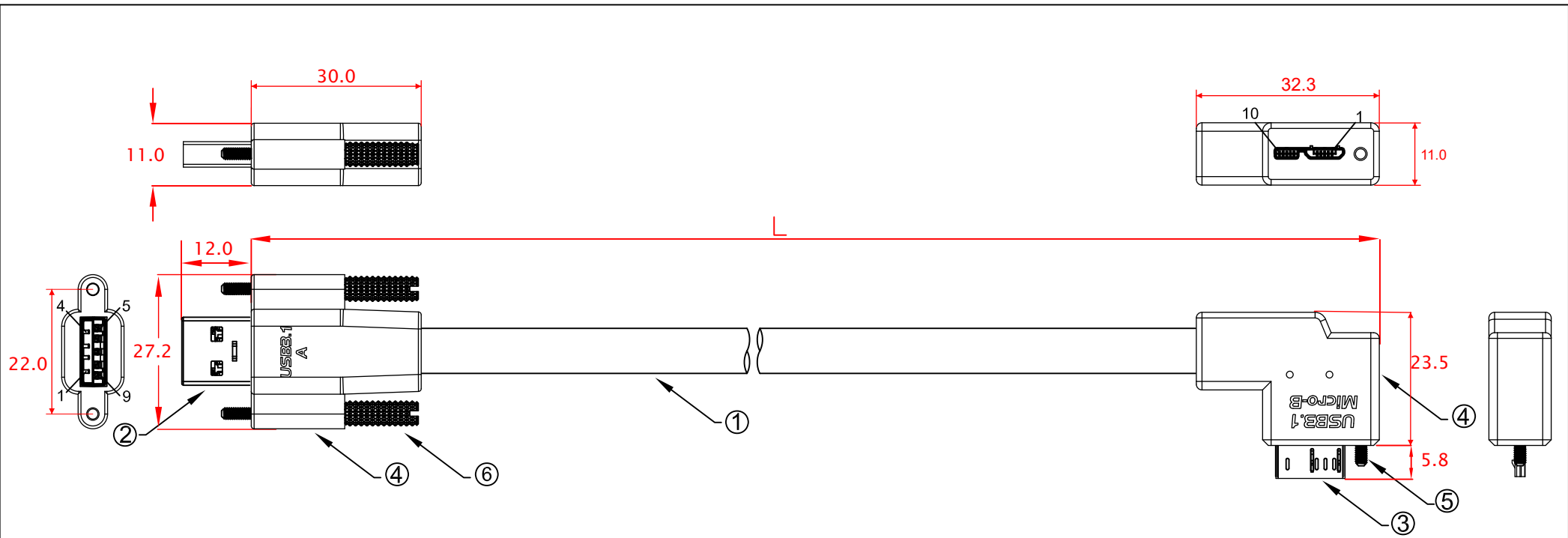

- L:
- CBL-RTPD3SABMBSH-1mRA 1000mm±10mm
 - CBL-RTPD3SABMBSH-2mRA 2000mm±20mm
 - CBL-RTPD3SABMBSH-3mRA 3000mm±20mm
 - CBL-RTPD3SABMBSH-4mRA 4000mm±30mm
 - CBL-RTPD3SABMBSH-5mRA 5000mm±30mm

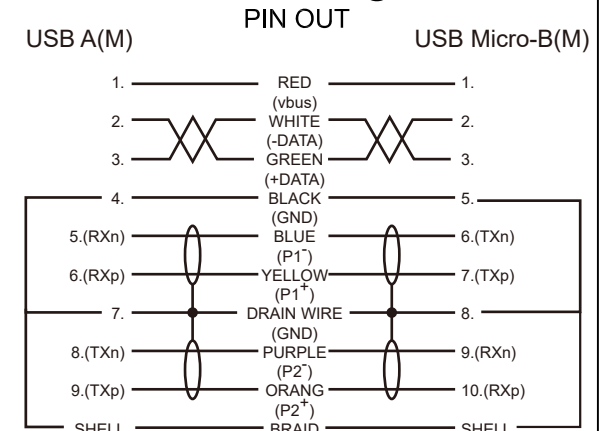

No	MATERIALS LIST:
1.	CABLE: 3 x (2 x 26 AWG)ST + 2 x 24 AWG O.D.:8.0mm COLOR:BLACK
2.	CONNECTOR:USB 3.0 A/M, 9P, BLUE INSULATOR SOLDER TYPE, NICKEL PLATED SHELL
3.	CONNECTOR:USB 3.0 MicroB/M, 10P, BLACK INSULATOR SOLDER TYPE, NICKEL PLATED SHELL
4.	PVC MOLDED HOUSING, BLACK COLOR
5.	SCREW:#4x23.32 M2
6.	SCREW:#4x34.5 M2

Jargy part no.	Client part no.	Approved	SCALE	UNIT
CBL-RTPD3SABMBSH-xmRA				mm
Drawing Name		Drawn	Date	REV.
USB 3.0 A to MicroB Cable M/M				1.0

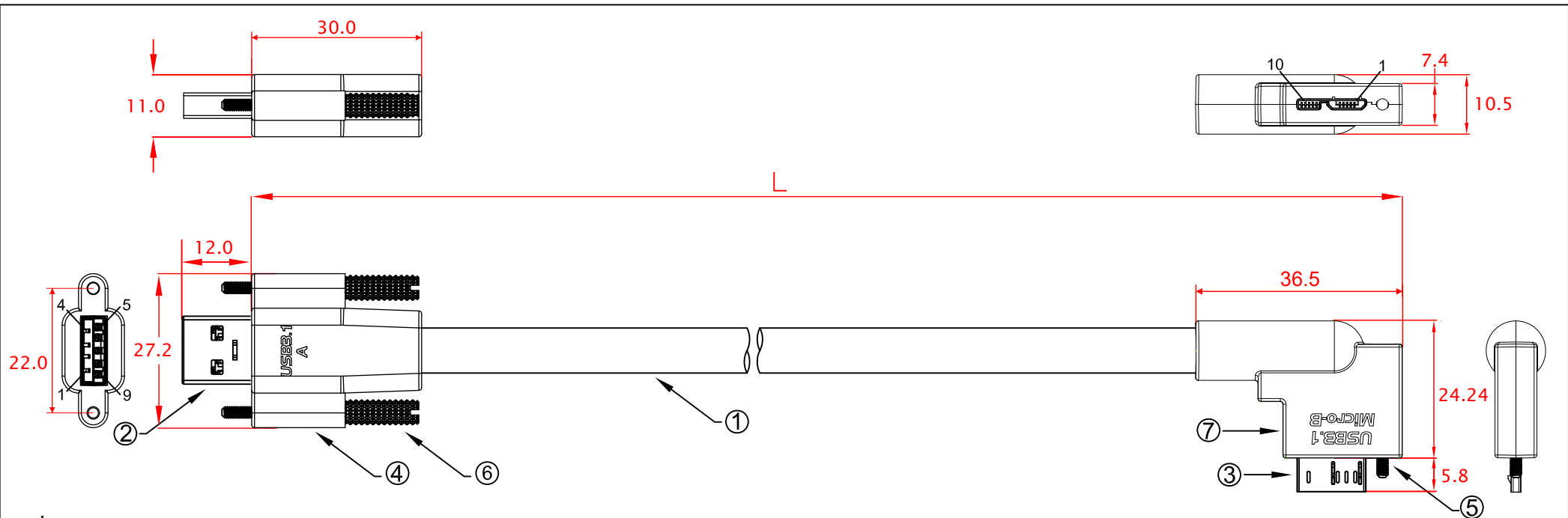

- L:
- CBL-RTPD3SABMBSHN-1mRA 1000mm±10mm
 - CBL-RTPD3SABMBSHN-2mRA 2000mm±20mm
 - CBL-RTPD3SABMBSHN-3mRA 3000mm±20mm
 - CBL-RTPD3SABMBSHN-4mRA 4000mm±30mm
 - CBL-RTPD3SABMBSHN-5mRA 5000mm±30mm

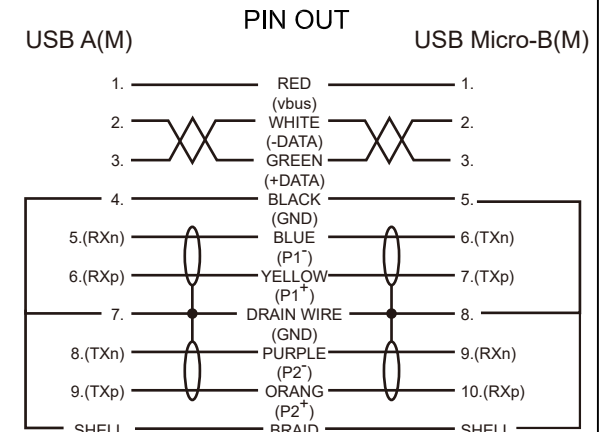

No	MATERIALS LIST:
1.	CABLE: 3 x (2 x 26 AWG)ST + 2 x 24 AWG O.D.:8.0mm COLOR:BLACK
2.	CONNECTOR:USB 3.0 A/M, 9P, BLUE INSULATOR SOLDER TYPE, NICKEL PLATED SHELL
3.	CONNECTOR:USB 3.0 MicroB/M, 10P, BLACK INSULATOR SOLDER TYPE, NICKEL PLATED SHELL
4.	PVC MOLDED HOUSING, BLACK COLOR
5.	SCREW:#4x23.32 M2
6.	SCREW:#4x34.5 M2
7.	ABS ASSEMBLY HOUSING, BLACK COLOR

Jargy part no.	Client part no.	Approved	SCALE	UNIT
CBL-RTPD3SABMBSHN-xmRA				mm
Drawing Name		Drawn	Date	REV.
USB 3.0 A to MicroB Cable M/M				1.0

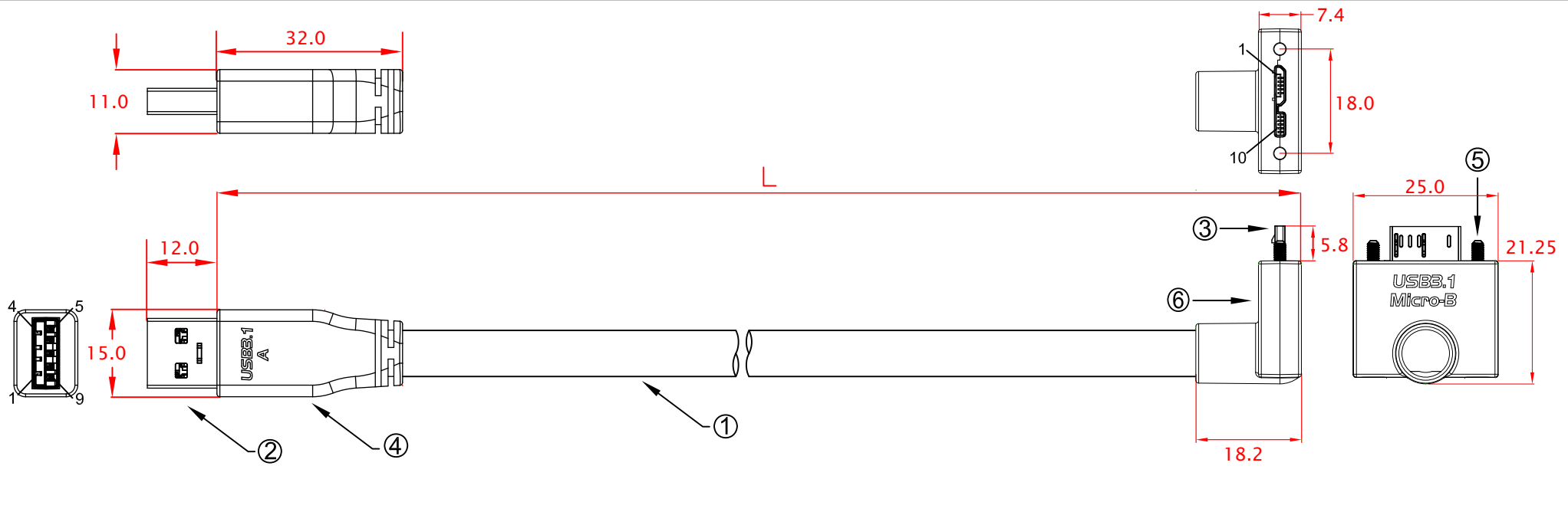

- L:
- CBL-RTPD3SABMBHN-1mUA 1000mm±10mm
 - CBL-RTPD3SABMBHN-2mUA 2000mm±20mm
 - CBL-RTPD3SABMBHN-3mUA 3000mm±20mm
 - CBL-RTPD3SABMBHN-4mUA 4000mm±30mm
 - CBL-RTPD3SABMBHN-5mUA 5000mm±30mm

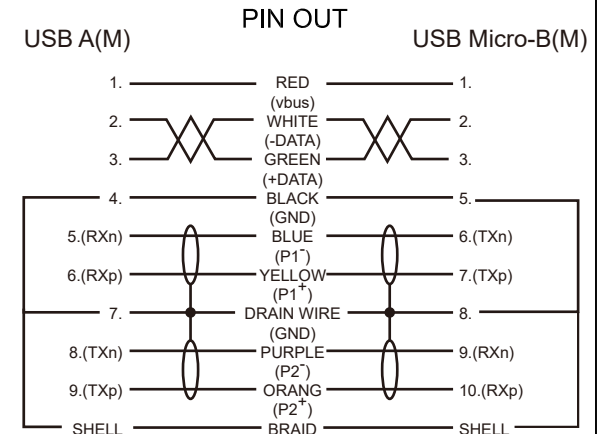

No	MATERIALS LIST:
1.	CABLE: 3 x (2 x 26 AWG)ST + 2 x 24 AWG O.D.:8.0mm COLOR:BLACK
2.	CONNECTOR:USB 3.0 A/M, 9P, BLUE INSULATOR SOLDER TYPE, NICKEL PLATED SHELL
3.	CONNECTOR:USB 3.0 MicroB/M, 10P, BLACK INSULATOR SOLDER TYPE, NICKEL PLATED SHELL
4.	PVC MOLDED HOUSING, BLACK COLOR
5.	SCREW:#4x23.32 M2
6.	ABS ASSEMBLY HOUSING, BLACK COLOR

Jargy part no.	Client part no.	Approved	SCALE	UNIT
CBL-RTPD3SABMBHN-xmUA				mm
Drawing Name		Drawn	Date	REV.
USB 3.0 A to MicroB Cable M/M				1.0

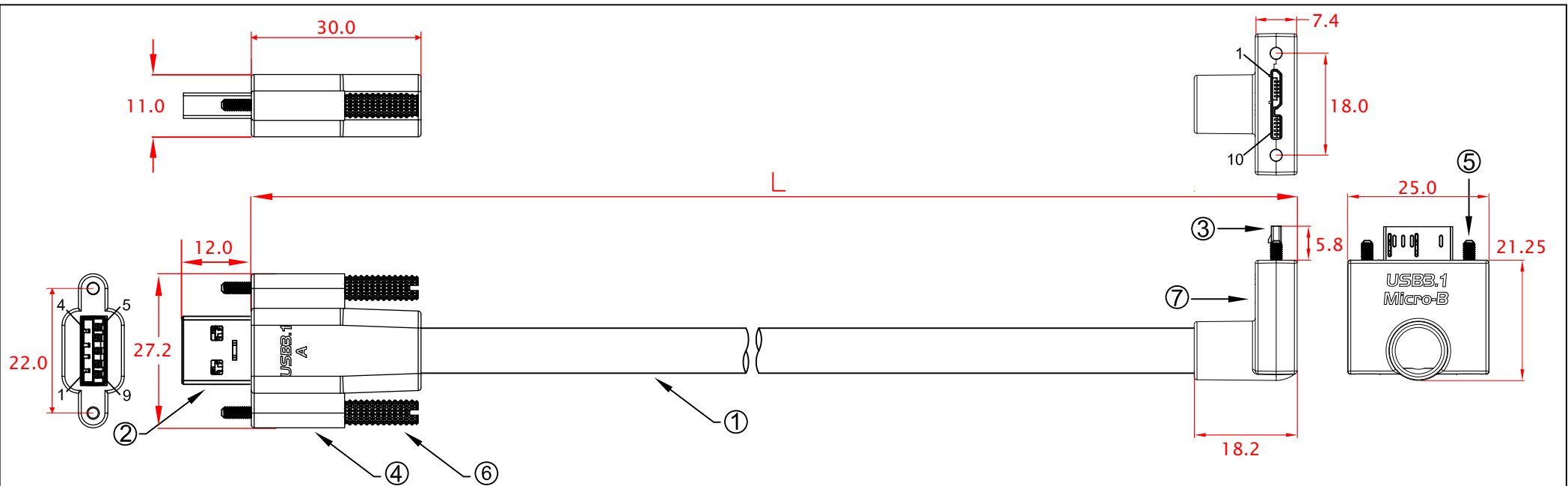

- L:
- CBL-RTPD3SABMBSHN-1mUA 1000mm±10mm
 - CBL-RTPD3SABMBSHN-2mUA 2000mm±20mm
 - CBL-RTPD3SABMBSHN-3mUA 3000mm±20mm
 - CBL-RTPD3SABMBSHN-4mUA 4000mm±30mm
 - CBL-RTPD3SABMBSHN-5mUA 5000mm±30mm

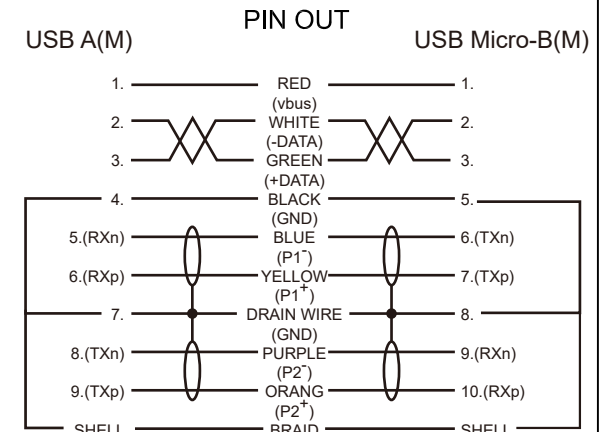

No	MATERIALS LIST:
1.	CABLE: 3 x (2 x 26 AWG)ST + 2 x 24 AWG O.D.:8.0mm COLOR:BLACK
2.	CONNECTOR:USB 3.0 A/M, 9P, BLUE INSULATOR SOLDER TYPE, NICKEL PLATED SHELL
3.	CONNECTOR:USB 3.0 MicroB/M, 10P, BLACK INSULATOR SOLDER TYPE, NICKEL PLATED SHELL
4.	PVC MOLDED HOUSING, BLACK COLOR
5.	SCREW:#4x23.32 M2
6.	SCREW:#4x34.5 M2
7.	ABS ASSEMBLY HOUSING, BLACK COLOR

Jargy part no.	Client part no.	Approved	SCALE	UNIT
CBL-RTPD3SABMBSHN-xmUA				mm
Drawing Name		Drawn	Date	REV.
USB 3.0 A to MicroB Cable M/M				1.0

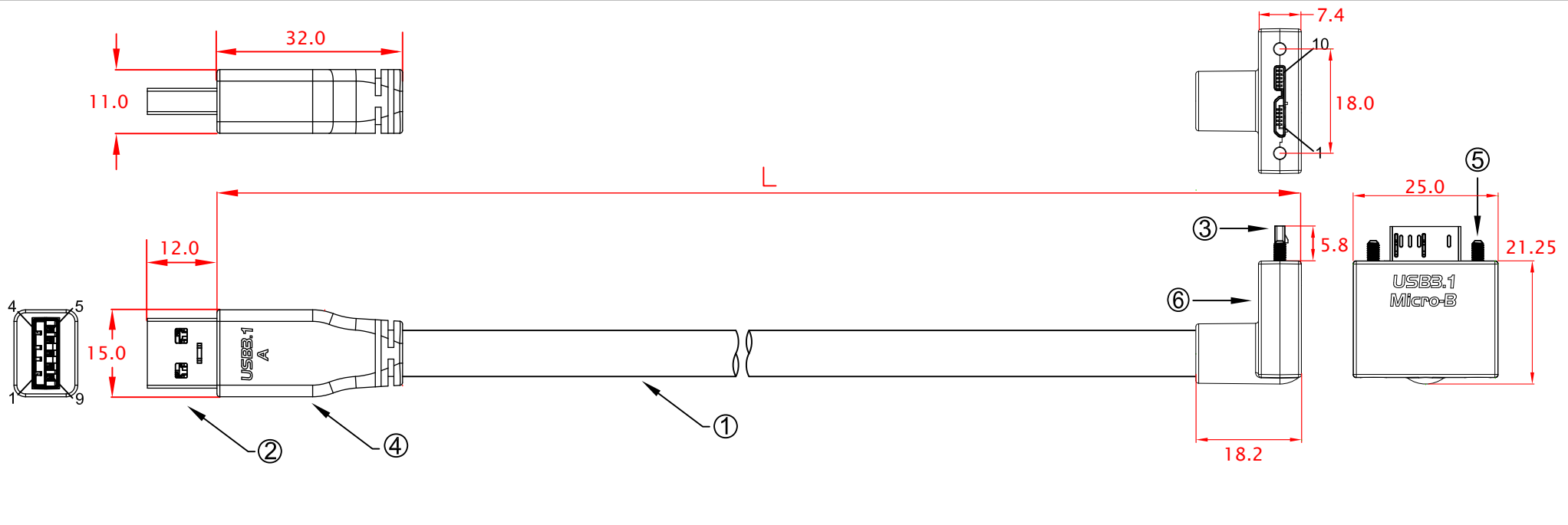

- L:
- CBL-RTPD3SABMBHN-1mDA 1000mm±10mm
 - CBL-RTPD3SABMBHN-2mDA 2000mm±20mm
 - CBL-RTPD3SABMBHN-3mDA 3000mm±20mm
 - CBL-RTPD3SABMBHN-4mDA 4000mm±30mm
 - CBL-RTPD3SABMBHN-5mDA 5000mm±30mm

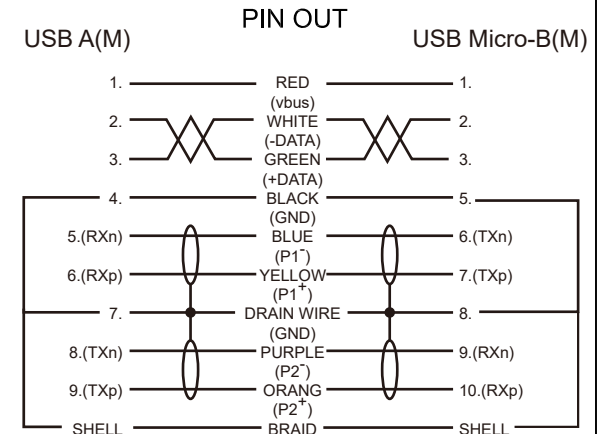

No	MATERIALS LIST:
1.	CABLE: 3 x (2 x 26 AWG)ST + 2 x 24 AWG O.D.:8.0mm COLOR:BLACK
2.	CONNECTOR:USB 3.0 A/M, 9P, BLUE INSULATOR SOLDER TYPE, NICKEL PLATED SHELL
3.	CONNECTOR:USB 3.0 MicroB/M, 10P, BLACK INSULATOR SOLDER TYPE, NICKEL PLATED SHELL
4.	PVC MOLDED HOUSING, BLACK COLOR
5.	SCREW:#4x23.32 M2
6.	ABS ASSEMBLY HOUSING, BLACK COLOR

Jargy part no.	Client part no.	Approved	SCALE	UNIT
CBL-RTPD3SABMBHN-xmDA				mm
Drawing Name		Drawn	Date	REV.
USB 3.0 A to MicroB Cable M/M				1.0

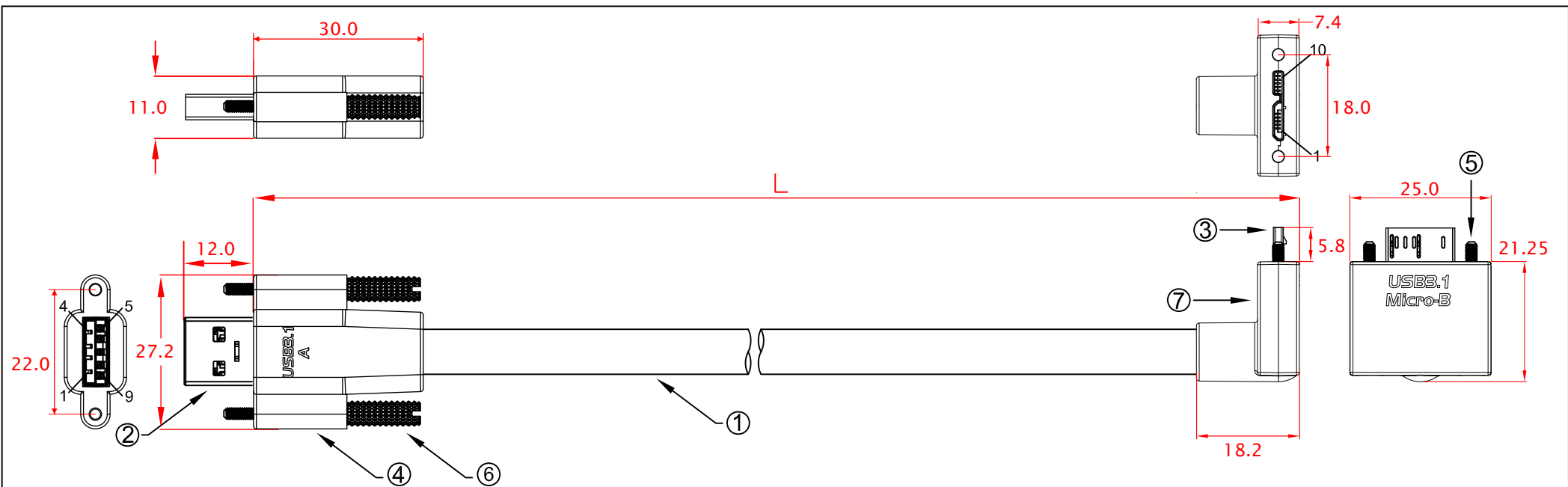

- L:
- CBL-RTPD3SABMBSHN-1mDA 1000mm±10mm
 - CBL-RTPD3SABMBSHN-2mDA 2000mm±20mm
 - CBL-RTPD3SABMBSHN-3mDA 3000mm±20mm
 - CBL-RTPD3SABMBSHN-4mDA 4000mm±30mm
 - CBL-RTPD3SABMBSHN-5mDA 5000mm±30mm

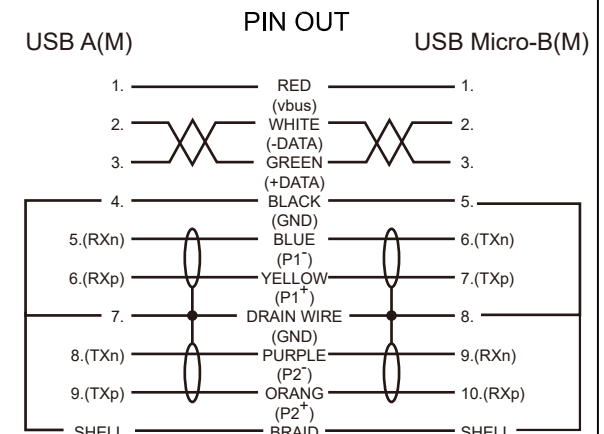

No	MATERIALS LIST:
1.	CABLE: 3 x (2 x 26 AWG)ST + 2 x 24 AWG O.D.:8.0mm COLOR:BLACK
2.	CONNECTOR:USB 3.0 A/M, 9P, BLUE INSULATOR SOLDER TYPE, NICKEL PLATED SHELL
3.	CONNECTOR:USB 3.0 MicroB/M, 10P, BLACK INSULATOR SOLDER TYPE, NICKEL PLATED SHELL
4.	PVC MOLDED HOUSING, BLACK COLOR
5.	SCREW:#4x23.32 M2
6.	SCREW:#4x34.5 M2
7.	ABS ASSEMBLY HOUSING, BLACK COLOR

Jargy part no.	Client part no.	Approved	SCALE	UNIT
CBL-RTPD3SABMBSHN-xmDA				mm
Drawing Name		Drawn	Date	REV.
USB 3.0 A to MicroB Cable M/M				1.0